



## Technical Data

# SoaperShelf® SOAP DISPENSER AND SHELF

# B-2014



Patented

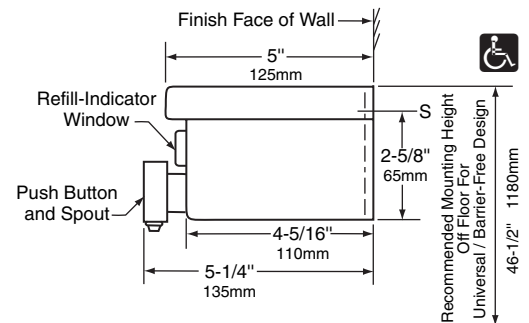
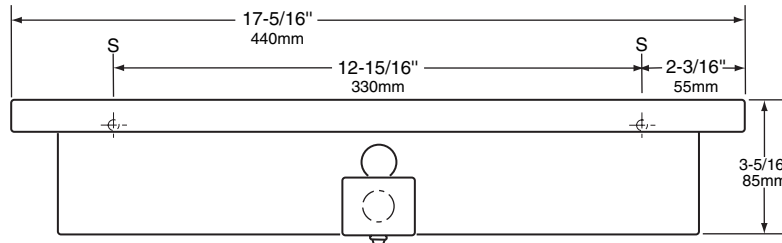

### MATERIALS:

**Shelf** — 18-8 S, type-304, 18-gauge (1.2mm) stainless steel with satin finish.

**Soap Vessel** — 18-8 S, type-304, 18-gauge (1.2mm) stainless steel with satin finish. Equipped with a clear acrylic soap refill-indicator window. Capacity: 80 fl oz (2.4 L).

**Valve** — Black, molded plastic push button and spout. Soap head-holding mushroom valve. Stainless steel spring. U-packing seal and duckbill. Corrosion-resistant to most soaps and detergents.

### OPERATION:

Corrosion-resistant valve dispenses commercially marketed all-purpose hand soaps. Valve operates with one hand, without tight grasping, pinching, or twisting of the wrist, and with less than 5 pounds of force (22.2 N) to comply with barrier-free accessibility guidelines (including ADAAG in the U.S.A.). Window indicates when refilling is required.

### INSTALLATION:

Secure unit to the wall using two #8 x 1-1/4" (4.2 x 32mm) sheet-metal screws furnished, at points indicated by an S. For plaster or dry wall construction, provide concealed backing to comply with local building codes, then secure wall plate with sheet-metal screws. For other wall construction, provide fiber plugs or expansion shields for use with sheet-metal screws, or provide 1/8" (3mm) toggle bolts or expansion bolts.

**Note:** Provide a minimum clearance of 5-1/4" (135mm) from top of shelf to underside of any horizontal projection. Push buttons should be located 44" (1120mm) maximum above the finish floor.

### SPECIFICATION:

Soap vessel and shelf shall be type-304 stainless steel with satin finish. Corrosion-resistant valve shall dispense commercially marketed all-purpose hand soaps. Valve shall be operable with one hand and with less than 5 pounds of force (22.2 N) to comply with barrier-free accessibility guidelines (including ADAAG in the U.S.A.). Soap vessel shall be equipped with a clear acrylic soap refill-indicator window and shall have a capacity of 80 fl oz (2.4 L). Manufacturer's service and parts manual shall be provided to the building owner/manager upon completion of project.

**Soap Dispenser And Shelf shall be Model B-2014 of Bobrick Washroom Equipment, Inc., Clifton Park, New York; Jackson, Tennessee; Los Angeles, California; Bobrick Washroom Equipment Company, Scarborough Ontario; Bobrick Washroom Equipment Pty. Ltd., Australia; and Bobrick Washroom Equipment Limited, United Kingdom.**